

E-security Through RFID

K. Amutha^{1*}, V. Vallinayagi²

¹Dept. of Computer Science, Manonmaniam Sundaranar University, Abishekapatti, Tirunelveli-12, Tamilnadu, India

²Dept. of Computer Science, Sri Sarada College For Women, Tirunelveli, India

DOI: <https://doi.org/10.26438/ijcse/v7si8.7578> | Available online at: www.ijcseonline.org

Abstract— Nowadays numerous applications based on Radio Frequency Identification (RFID) systems are developed and also applied to different areas such as building system, health, agriculture, hospitals industry and educational institution. RFID technology means Radio Frequency Identification include automatic wireless identification using electronic tags such as passive and active readers. In this paper, we try to solve the attendance problem in educational sector using this technology. The purpose of this function is to monitor the student attendance to eliminate the waste of time instead of manual attendance process. Therefore they capture the face to face recognition and also allocate the suitable attendance scores for further process.

Keywords- RFID, Attendance, Active tag, Reader, face recognition.

I. INTRODUCTION

The appearance of electronic pattern for learning compared to traditional method and availability of all information available in internet. Now a days students were not interested to attend the conference in person, Due to their lack of participation, extracurricular activities are not so important in the proper concern and may have stop the students for attending the lecture. According to these, the professors and the admins are not enthusiastically participated and also the student-faculties relationships are not broken. In some cases, the format should be in group discussion, surprise test, additional marks in class. These strategies are mainly used to reduce the time and manpower. Then the attendances are maintained by the course coordinator and also lead to individual errors. While solving this problem it should appear in an effective and efficient manner. This RFID technology is very low cost and also it will be more accurate in a timely manner. It is easy to identify, secure, examine and do inventory. It can be used as a number of small tags to identify the information to a suitable reader. This will improve their efficiency and also calculate the accurate data.

II. LITERATURE REVIEW

A number of related works exist in literature, application of RFID Technology in different areas and specifically the area of academic attendance. In [5], the authors designed and implemented a model of a secured and portable embedded reader system to read the biometric data from the electronic passport. The authors attempted to solve problems of reliability, security and privacy in E-passports by authenticating holder online using Global System of Mobile

Communications (GSM) network. The GSM network is the main interface between identification centre and the e-passport reader. The data is protected between server and e-passport reader by using AES to encrypt data for protection. While transferring data through GSM network should be kept confidential. Author in [6] reviewed the current research application of RFID in different areas with prominence on application for supply chain management and developed a framework to classify literature which enables swift and easy content analysis to identify areas for future research. Authors in [9] reviewed the use of RFID in an integrated-circuit package house to solve inventory transaction issues. His study suggests that RFID contributes significant improvements to the water receiving process and the inventory transaction process that reduce labor cost and man-made errors. In [10], an automated attendance management system was implemented both in electronic and mobile platform using stationary matrix RFID reader with four circulatory polarized antennas and Symbol MC9000-G handheld RFID reader respectively. In the electronic platform, the attendance management system depicts a simple client (antennae placed at lecture hall entrance) and server (privileged student database) system. Students can visually see their names when they entered into class, on the screen and they are assured that their presence has been entered in the tutor's database. However, one important drawback in this system is the RFID tag and reader should be close in distance to improve its performances. In [1], an automatic attendance system using bio metric verification technique was proposed. The fingerprint verification was achieved by extraction of abnormal point on the ridge of fingerprint technique. The verification confirms the authenticity of an authorized user by performing one to one

comparison of a captured fingerprint templates against the stored templates in the database. The proposed automatic attendance system signals either true or false based on logical result of previous one to one verification of person's authenticity [2]. Authors in [3] also proposed biometric system using employees fingerprint for attendance automation of an organization. Consequently, authors in [4] proposed student wolf pack club tracking system to speed up the process of student wolf pack club ticket distribution for event. Our proposition enables a simple, reliable and cost effective model for face to face lecture halls attendance management that uses existing student ID card microchip as the passive tag with additional SMS to parents as summary.

III METHOD AND EQUIPMENT

The main reason of an RFID system used in this application area is to recognize the presence and absence of the student data. It is to be transmitted wirelessly by mobile device called a tag which is read by an RFID reader and processed according to the automatic instructions on the personal computer (PC). The effort with which RFID can be included into current operations depends on the depicts a simple client (antennae placed at classroom entrance) /server (privileged student database) system. Students can visually see their names in the entered class on the screen and they are assured that their presence has been entered in the instructor's database. However, one main problem in the system is the RFID tag read rate disgrace enormously as it came closer to electronic devices. In [1], an automatic attendance system using fingerprint verification technique was proposed. The fingerprint method verification was achieved using extraction of abnormal point on the ridge of user's fingerprint or minutiae technique. The verification confirms the authenticity of an authorized user by performing the comparison of a captured fingerprint template against the stored templates in the database. The proposed automatic attendance system signals either true or false based on logical result of previous one to one verification of person's authenticity [3]. Authors [2] also proposed biometric system using fingerprint identification for attendance automation of employees in an organization. As a result, authors in [4] proposed student wolf pack club tracking system to simplify and speed up the process of student wolf pack club ticket allocation for athletic event. Our suggestion emphasize a simple, reliable and cost effective model for face-face classrooms' attendance management that uses existing student ID card chip as the passive tag with additional short message services to parents also. The proposed system provides solution to lecture attendance problem through synchronized hardware and software design handshaking data communications between RFID tag and RFID reader serially interfaced to the digital computer system.

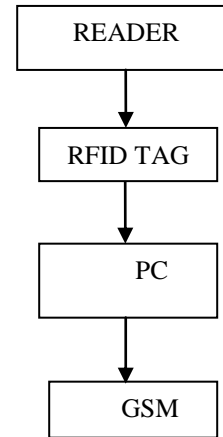

Fig 1. Block diagram of the RFID-Based Students Attendance Management System.

IV.HARDWARE DESIGN CONCERNS

In this system the item is connected with a chip and also combined with antenna called tag. Each and every tag had a reader and the radiofrequency waves should be scanned by readers. It also checks the data and the information and finally it will be stored in a database. Several mechanisms such as tag, reader, database, etc. The advantages of this system are the tags that can be combined in to student ID card and also no wireless communication between the tag and the reader. Tags have fixed serial code that are not in stable state. The reader has two connectors. It is connected to send and receive the signal through the cables. A female DB9, and a 2.1mm DC Jack shown in Fig. 2. The female DB9 provides the RS232 serial output from the reader. Pin 2 is the transmit signal output (TXD). It was connected to receive (RXD) signal input of the computer via the DB9 to USB interface cable. Pin 5 is the common ground reference signal and is connected to the common ground of the computer via the DB9 to USB interface cable DC power jack is used to power the reader. The centre pin of the jack is connected to the positive side of a 9-12V DC power supply. The outer conductor is connected to the negative side of the power supply (9V DC battery).

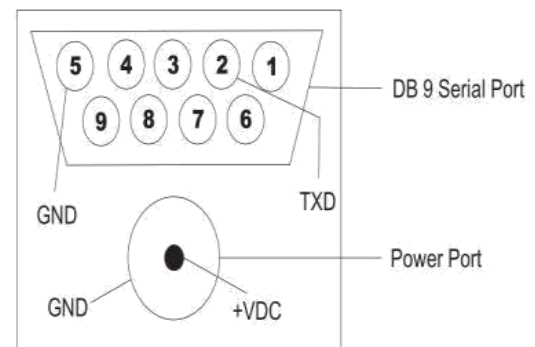

Fig.2. Front view of the RFID reader's connector ports

A single antenna is required for power and reading the passive transponders (tags). The antenna is used in series resonant circuit, formed by capacitor, inductor and resistor. The antenna is a square antenna 9cm X 9cm with 83 turns, inductance of 1.58mH with 10 ohm resistance. The reading range is spherical with the antenna located at the equator. The minimum and maximum read range is determined by the surface area of the tag. The system was set up as shown in figure 2.0 with the following steps:

a:Connect Male head of the RS232 serial cable to Female DB9 port of the RFID reader.

b:Connect USB end of the serial cable to one of the USB ports of the computer system being used.

c:Connect 9V dc battery to the Adapter and then the adapter to the RFID reader's power jack.

d:Determine the COM port of computer and that it corresponds to the one used within the programming code written to control system.

V.SYSTEM TESTING AND OPERATION AND DISCUSSION

In educational sectors, the Rfid tags leads to believe the possibility of utilization for monitoring the attendance of students . At the same time ,every students number were associated with this tag and also the serial number is connected with a database entry. If the students are entered, their entries will be verified in the database. The webcam can reduce the attendance checking and also this is used to cross check the extra events. Finally the attendance details are in type of reports like daily, monthly, weekly and also inform the students feedback to their parents.

When it passes the radio frequency field , the tag must be activated. First the program verifies if the tag is valid or invalid. If it is valid, the database program will allow the students attendance for the course. If it is invalid ,the required notification will be passed and the tag has not been registered. So for each and every student , entering and leaving the class the student must bring their tags close to the reader. After the reader reads the tag, the students entrance time and exit time must be read again and again. Using this record maintenance, the SMS message is informed to the parents mobile number. Each course coordinator have this tag to control the starting and ending session with extra time delay for end of the class activation to permit every student to verify the exit time on the reader. The lecturer can call for information for each and every student can ask their queries. Therefore by using these active tags the interaction of the students are developed. This will increase the entire cost of the system. At the end of the semester, the professor can evaluate the students current status (attendance scores) for a particular course. The special metrics could be frequency of attending the class, time duration in class and punctuality. Thus the program gives the output as: student name, roll

number, tag ID number, department, the course in question and the attendance status based on the individual metrics.

VI. CONCLUSION

In this technology we have so many complex applications will use the capability of RFID to send, receive, store and forward data to a remote area. RFID has many applications that can be expected. In this paper, we have to implement the concept of RFID technology, the students attendance system will automatically updated . It allows the students that can easily fill their attendance scores just using their ID cards by the suitable reader. The RFID reader must locate at both the entrance and exit of the lecture rooms. We hope that this system can easily verified by the student's faculty attendance by monitoring the face to face recognition .It also provided a new, accurate and fewer amount of taking students attendance in various institutions .

REFERENCES

- [1]Chitresh, S and Amit K (2010),”An efficient Automatic Attendance Using Fingerprint Verification Technique” ,International Journal on ComputerScience and Engineering (IJCSE),Vol 2 No.pp 264-269
- [2]Henry.SS. Arivazhagan and Ganesan(2003),Fingerprint verifications using wavlet Transform ,International Conference on computational and Multimedia Applications, 2003.[3]
- [3][Maltoni D, D. Maio, A. K. Jain, S. Prabhaker (2003), “Handbook of Fingerprint Recognition”, Springer, New York,Pp 13-20.
- [4] Victor S, Jonathan M,Reece J,and Lemire(2003),”StudentWolfpackClub TrackingSystem”, North Carolina State University. USA.
- [5] Nambiar A.N. (2009),” A supply chain perspective of RFID Systems”, World Academy of Science, Engineering and Technology Journal, Volume 6,pp1-5.
- [6] Mohamed A.B, Abdel-Hamid A and Mohammed K.Y.,(2009), ”Implementation of an Improved secure system detection for E passport by using EPC RFID tags”, World Academy of Science, Engineering and Technology Journal, Volume 6,pp1-5.
- [7]Dawes A.T. (2004),”Is RFIDRight for Your Library”, Journal of Access Services, Volume 2(4), pp 7-13.
- Longe O.O.(2009),”Implementation of Student Attendance System using RFID Technology”, B. Tech Project Report, Ladoke Akintola University of Technology, Ogbomoso, Nigeria
- [8]Liu C.M. and chen L.S.(2009),”Applications of RFID technology for improving production efficiency in an Integrated –circuit packaging house,”International Journal ofProduction Research, vol47,no.8,pp.2203-2216.
- [9]RFID SensNet Lab(2005), A white paper on Automatic attendance System Texas A&M University, Texas, USA
- [10]Bardaki, C.Kourouthanassis, P. and Pramatarı,K,(2012), Deploying RFID-Enabled Services in the Retail Supply Chain:Lessons toward the Internet of Things, Information Systems Management, Vol.29:no.3,pp 233-245.
- [11]Stockman, H. (1948). Communication by Means of Reflected Power, Proceedings of the Institute of Radio Engineers, 36(10) 1196-1204.
- [12]Strassner, B. & Chang, K. (2003). Integrated antenna system for wireless RFID tag in monitoring oil drill pipe, Proceedings of the

- International Symposium on Antennas and Propagation Society, IEEE, 1 208-211.
- [13]Terez, T.J. (1992), Bar codes move into maintenance management, *Hydraulics & Pneumatics*, 45(4) 36.
- [14]Domdouzis, K., Kumar, B. & Anumba, C. (2007). Radio-Frequency Identification (RFID) applications: A brief introduction, *Advanced Engineering Informatics*, 21(4) 350-355.
- [15]Fontelera, J. (2005), RFID exploration, *Converting Magazine*, 23(9) 28-32.
- [16]Hunt, V.D., Puglia, A.& Puglia, M. (2007), *RFID-A Guide to Radio Frequency Identification*, Wiley-Interscience.
- [18]. Ko, C.H. & Wang, S.F. (2007), Overcoming difficulties in weekly work planning. *Research Journal of Applied Sciences*, 2(7) 823-827.

AUTHORS PROFILE

K. Amutha pursued Bachelor of Computer Science from Manonmaniam Sundaranar University in 2003 and Master of Computer Applications in 2006 and Master of Philosophy in 2007 at the same time. Now she is pursuing Ph.D in the Research centre of Sri Sarada College for Women under the affiliated to Manonmaniam Sundaranar University .Her main research is image based security with RFID technology. Now she is working anAssistant Professor in the Department of Computer Applications , Sri sarada College for women since 2013.
